



R07MS

**DATE: JANUARY 16, 2008**

**TO: U.S. DEALERS**

**SUBJECT: RECALL R07MS BRAUN WHEELCHAIR LIFT  
NONCOMPLIANCE-THRESHOLD  
WARNING SIGNAL RECALL**

This notice is sent to you in accordance with the requirements of The National Traffic and Motor Vehicle Safety Act.

Blue Bird Corporation has decided that certain 2006 and 2007 model year Blue Bird All American, Vision and Micro-Bird school buses manufactured from July 16, 2005 through August 29, 2006 and equipped with The Braun Corporation Series 900 wheelchair lift fail to conform to the requirements of Federal Motor Vehicle Safety Standard No. 571.404 "Platform Lift Installation for Motor Vehicles". Blue Bird is conducting a recall to correct this noncompliance.

If our records indicate affected units were delivered in your service area, a printout identifying affected units is enclosed. **Note: Blue Bird does not maintain The Braun Corporation wheelchair lift serial numbers. A reply sheet is provided to each owner for recording the Braun wheelchair serial number for each body number. This reply sheet must be returned to Blue Bird.**

It is the distributor's responsibility to verify that the correct owner name, address and telephone number is provided for each listed vehicle. Any corrections or updates should be made on BBOND. Addresses that cannot be updated on BBOND should be forwarded to the Recall Administrator.

If you have in your possession or have sold a vehicle that was purchased from another dealer that may be affected by this recall, please notify me at 478-822-2242.

Labor time authorized to perform recall R07MS is 0.6 hours (18 minutes) per bus.

Blue Bird dealers that are also Braun Corporation dealers must file for warranty reimbursement directly to The Braun Corporation. Blue Bird dealers that are not Braun Corporation dealers may submit warranty applications to Blue Bird VIA ClaimTrac (use create campaign/bulletin claim).

**BLUE BIRD CORPORATION**  
402 Blue Bird Blvd. PO Box 937 • Fort Valley, Georgia 31030  
(478) 825-2021

**All claims must have the The Braun Corporation wheelchair lift serial number indicated in the text section of the warranty claim. Claims for inspection and correction of the noncompliance will only be accepted for wheelchair lifts with body serial numbers in the recall population.**

Federal law requires that any vehicle lessor receiving this recall notice must forward a copy of this notice to the lessee within ten days.

Dealers are reminded of their responsibilities under section 154 of The National Traffic and Motor Vehicle Safety Act of 1991. Dealers are required to complete modifications or repairs on units in their inventory before delivering to the final owner. Reference Blue Bird Body Company Distributor Memo No. 42-92.

Questions regarding this recall campaign should be directed to me at (478) 822-2242.

Thank you,

A handwritten signature in cursive script that reads "Bill Coleman".

Bill Coleman  
Corporate Recall Administrator  
Blue Bird Corporation  
478-822-2242  
bill.coleman@blue-bird.com



**BLUE BIRD**

**R07MS**

January 16, 2008

Dear Blue Bird Owner:

This notice is sent to you in accordance with the requirements of the National Traffic and Motor Vehicle Safety Act.

Blue Bird Corporation has decided that certain 2006 and 2007 model year Blue Bird All American, Vision and Micro-Bird school buses manufactured from July 16, 2005 through August 29, 2006 and equipped with The Braun Corporation Series 900 wheelchair lift fail to conform to the requirements of Federal Motor Vehicle Safety Standard No. 571.404 "Platform Lift Installation for Motor Vehicles".

This non-conformity may result in a passenger approaching the exposed lift doorway without the audible alarm alerting them of their proximity to the threshold. As a result, they could fall out of the door and be injured or killed. Blue Bird is conducting a recall to correct this noncompliance.

To correct this condition, you will need to verify the threshold warning system is within specifications as indicated in the attached Braun Corporation service letter labeled 34273. The inspection and, if necessary, correction must be performed by a qualified technician.

If you prefer, your Braun Corporation dealer will perform the inspection and, if necessary, correct the noncompliance at no cost to you. If you are not reimbursed, you may contact your Blue Bird dealer for assistance. Labor time required to perform this recall is 0.6 hours (18 minutes) per wheelchair lift.

If you have any problems obtaining the needed repair or wish to schedule service with an approved Braun technician, please contact The Braun Corporation Product Support at 1-800-946-7513. A Braun Product Support representative will arrange for prompt attention to your lift.

Your Blue Bird bus(es) equipped with a Braun Corporation wheelchair lift is identified by body number on the enclosed yellow reply sheet. Your bus(es) equipped with the non-conforming Braun wheelchair lift must have the wheelchair lift inspected and and if necessary modified according to the attached Braun Corporation service letter labeled. 34273.

**BLUE BIRD CORPORATION**  
402 Blue Bird Blvd. PO Box 937 • Fort Valley, Georgia 31030  
(478) 825-2021

**Note: Blue Bird does not maintain Braun Corporation wheelchair lift serial numbers. A reply sheet is provided for recording the Braun Corporation wheelchair lift serial number and date of inspection/modification for each body number. When your wheelchair lift(s) have been inspected and, if necessary, corrected you must complete the enclosed recall completion reply sheet along with the lift serial number document and return to Blue Bird in the pink postage paid reply envelope.**

If you no longer own the subject bus(es), please complete the appropriate section of the pink reply sheet and return to Blue Bird in the enclosed pink postage prepaid envelope.

If the modifications/repair directed by this notification was performed on your bus prior to the receipt of this recall notification, complete and sign the recall reply sheet and attached a copy of the work order/invoice. Mail the documents in the pink self-addressed postage paid envelope included with the recall notification to Blue Bird for reimbursement consideration.

Federal law requires that any vehicle lessor receiving this recall notice must forward a copy of this notice to the lessee within ten days.

If Blue Bird Body Company should fail to or is unable to remedy this condition without charge to you, you may contact:

**ADMINISTRATOR  
NATIONAL HIGHWAY TRAFFIC SAFETY ADMINISTRATION  
1200 NEW JERSEY AVENUE, SE  
WASHINGTON, D.C. 20590**

or you may call The National Highway Traffic Safety Administration toll free at:

1-888-327-4236  
TTY: 1-800-424-9153  
or got to: <http://www.safecar.gov>

Questions regarding this recall campaign should be directed to me at (478) 822-2242.

Thank you,



Bill Coleman  
Corporate Recall Administrator  
**BLUE BIRD CORPORATION**

## Recall R07MS Completion Reply Sheet

When your Braun Corporation wheelchair lift(s) have been inspected and, if necessary corrected, please complete the form below and return to Blue Bird in the pink reply envelope provided. Completing and returning this form will prevent you from receiving follow up notices on this recall.

Blue Bird Body Number	Braun Serial Number	Date Lift Inspected	Date lift Repaired	Inspected/Repaired by

Form Completed by: \_\_\_\_\_  
(Print Name)

Company: \_\_\_\_\_

Address: \_\_\_\_\_

City: \_\_\_\_\_

State: \_\_\_\_\_

Zip: \_\_\_\_\_

Signature: \_\_\_\_\_

Date: \_\_\_\_\_

# Service Bulletin 34273

October 2007

Instructions for Braun Corporation "Public and Private Use" Dual Parallel Arm Lift Threshold Sensitivity Evaluation and NHTSA Compliance Applicable for NL, NCL and NVL Series Lifts

**THE BRAUN CORPORATION**  
"Providing Access to the World"®

International Corporate Hdqrs: P.O. Box 310 Winamac, IN 46996 USA  
1-800-THE LIFT® (574) 946-6153 FAX: (574) 946-4670

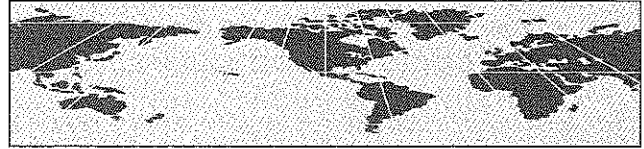

**Introduction:** Per NHTSA requirements - a visual and/or audible warning\* is to activate if the threshold area is occupied when the lift platform is at least one inch below floor level.

\* **Note:** A visual and audible warning system is required for Public Use lifts. Braun Private Use lifts feature an audible warning only.

This bulletin outlines the procedures required for testing lift threshold sensitivity (details below). Check the activation of the threshold warning system as outlined. If the threshold warning functions as intended - **disregard** the remainder of the bulletin. The lift threshold warning is NHTSA compliant.

If there is a non-responsive location on the threshold plate (alarm does not activate), correct the activation sensitivity as detailed in the retrofit instructions on pages 2 and 3 of this bulletin. Test the threshold sensitivity again to ensure proper activation.

**Note:** For clarity, the photos appearing in this bulletin depict a lift base plate weldment, threshold plate and tape switches only.

## Threshold Sensitivity Test

1. Turn Lift Power switch ON. Deploy the lift platform fully to the ground.
2. Apply hand pressure on the center of the threshold plate as shown in Photo A. The visual and/or audible threshold warning\* should be activated when you push down.

Repeat the sensitivity test procedure at positions A-E shown in Figure 1.

3. If the threshold alarm is activated at all positions, no further procedures are required. The lift threshold sensitivity meets NHTSA FMVSS 403/404 requirements.

If the threshold alarm is not activated at all positions, perform the retrofit procedures detailed on pages 2 and 3 of this bulletin. Repeat the sensitivity test procedures following the retrofit. If the lift still does not meet the requirement, contact a Braun Corporation Product Support representative at 1-800-THE LIFT®.

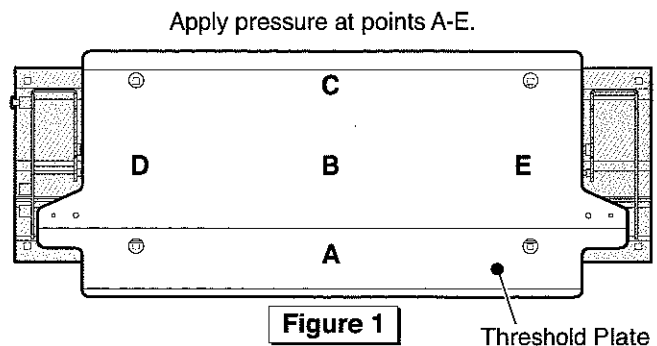
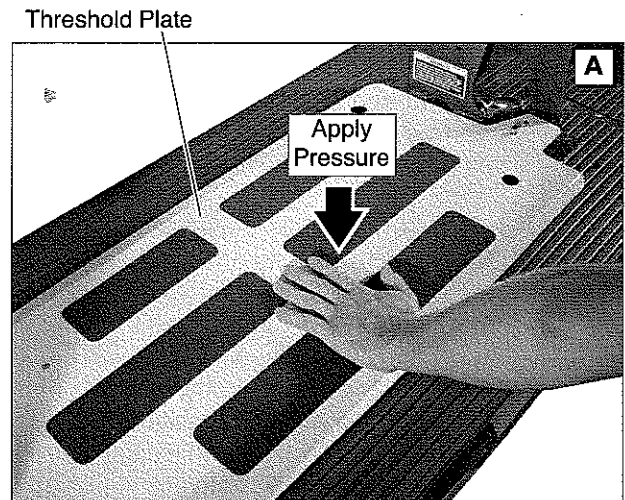

# Lift Threshold Sensitivity Bulletin 34273

## Threshold Sensitivity Retrofit Instructions

1. Turn Lift Power switch ON. Deploy the lift platform fully to the ground.
2. Remove the threshold plate. Loosen and remove two Allen head shoulder bolts securing the plate (see Photos B and C). Keep bolts. Slide the plate outward and lift to remove it (four keeper standoffs engage key-hole slots). See Photos E, F and G.
3. An adhesive-backed plastic tag is supplied to serve as an alarm activation shim (minimal thickness required to activate the highly sensitive alarm strip switches). Cut the plastic tag in two halves. The plastic tags (shims) will be affixed to the bottom side of the threshold plate (positioned as shown and detailed below).

Turn threshold plate over. See Photo D. The strip switches typically leave an impression (mark) on the yellow plate from use. Use the impression of the inboard strip switch as a centerline for shim positioning (or measure to establish position).

Position each shim 9" from the center of the threshold plate (see Photo D). Align the tags with the strip switch centerline. Clean the surface as detailed below and affix the adhesive-backed tag to the plate (**press firmly**).

**Note:** Clean the surface with isopropyl alcohol before affixing the tag. Use a clean cloth or paper towels. Do not use oily shop rags. Wipe surface free of residue with dry portion of cleaning cloth.

**B**

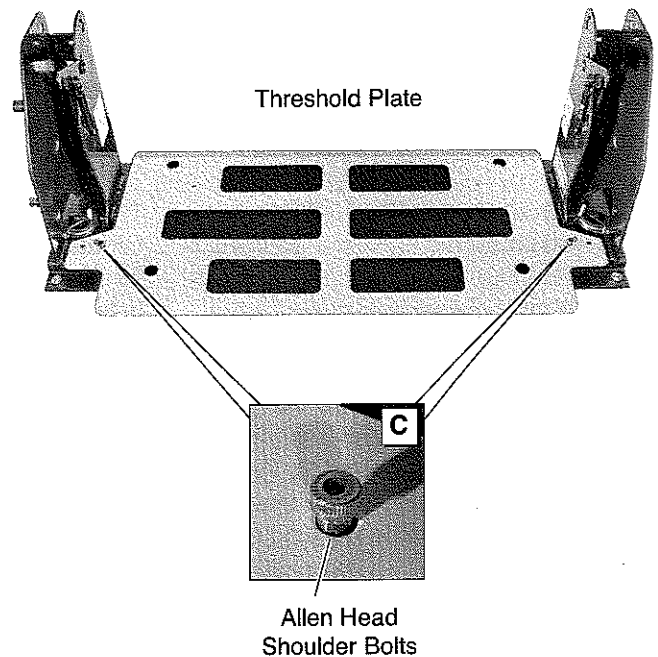

**D**

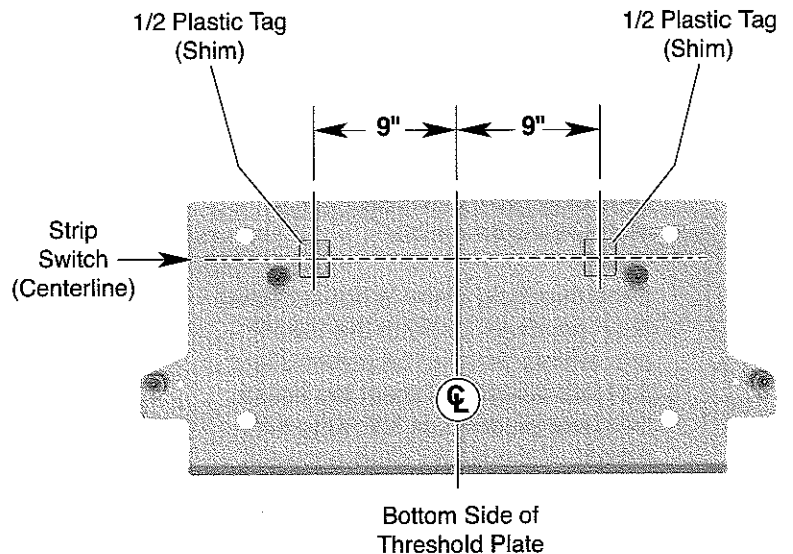

# Lift Threshold Sensitivity Bulletin 34273

## Threshold Sensitivity Retrofit Instructions

4. Reposition the threshold plate (with shim). Align the keeper standoffs (studs) on the bottom of the threshold plate with the base plate keyhole slots. See Photos E, F and G. Insert studs and **carefully** slide the plate inward (engage slots fully).

When repositioning the threshold plate - **note the following:**

**Ensure** all hoses and wiring harnesses routed through the base plate gutter are positioned fully in the gutter and not located anywhere they could potentially interfere with activation of the tape switches. See Photo E.

**Note:** Spraying a light mist of glass cleaner (or other) to the strip switches will aid in the plate sliding easier into position. See Photos E, F and G.

**Ensure** all four keeper standoffs engage the base plate keyhole slots.

5. Reinstall the two Allen head shoulder bolts previously securing the plate (see Photo B and C). Tighten bolts securely.
6. Repeat the sensitivity test procedures outlined on page 1.

If the threshold alarm is activated at all positions, no further procedures are required. The lift threshold sensitivity meets NHTSA FMVSS 403/404 requirements.

If the threshold alarm is not activated at all positions, contact a Braun Corporation Product Support representatives at 1-800-THE LIFT®.

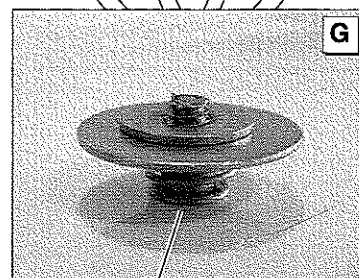
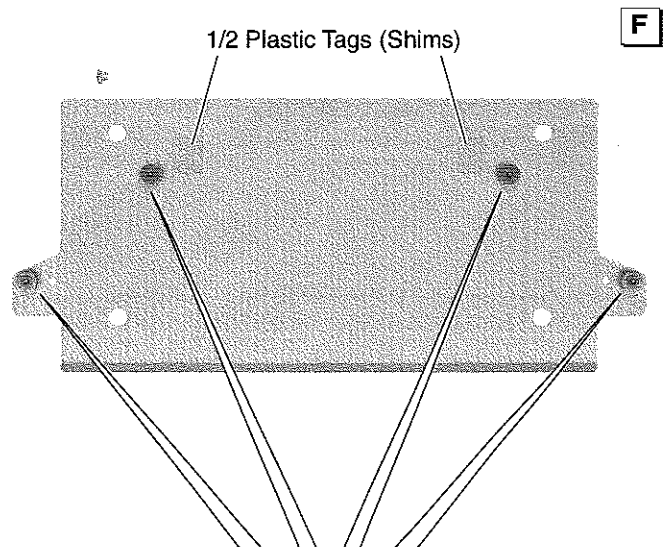
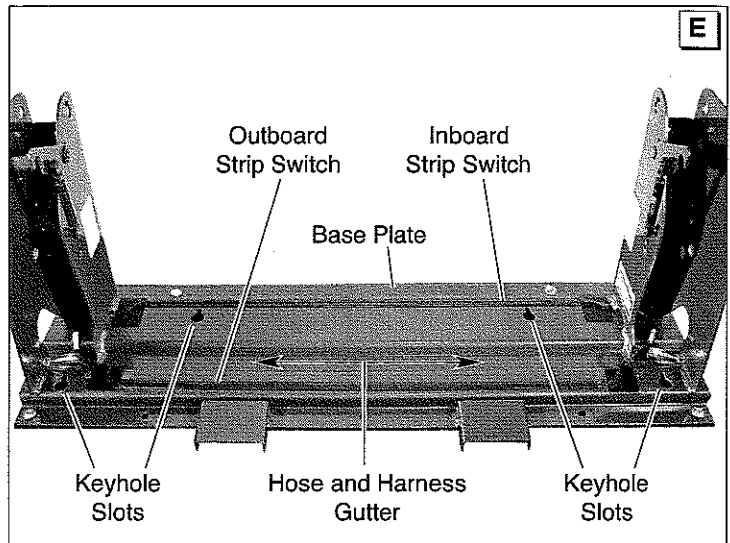

Keeper Standoffs  
(Engagement Studs)