

R09PE

DATE: JUNE 25, 2009

TO: U.S. DEALERS

**SUBJECT: RECALL R09PE VANDAL LOCK STARTER INHIBIT
NONCOMPLIANCE**

This notice is sent to you in accordance with the requirements of The National Traffic and Motor Vehicle Safety Act.

Blue Bird Corporation has decided that certain 2003 through 2010 model year Blue Bird All American rear engine school buses manufactured from July 16, 2003 through April 10, 2009 and equipped with optional plug style vandal lock fail to conform to the requirements of Federal Motor Vehicle Safety Standard No. 571.217.S5.2.3.3.

The subject buses may be started and/or operated with the emergency door or rear emergency window vandal lock engaged. A locked emergency exit may result in personal injury or death in the event of a vehicle crash. Blue Bird is conducting a recall to correct this condition. The subject buses must be modified according to the enclosed instructions for Recall R09PE.

If our records indicate buses subject to this recall were delivered in your service area, a printout identifying affected buses is enclosed. **Dealers should verify correct owners and assure that complete mailing and shipping addresses are provided for each listed owner.**

If you have in your possession or have sold a bus that was purchased from another dealer that may be affected by this recall, please notify me at 478-822-2242.

Labor time required to perform recall R09PE on buses **without** a pass-through luggage box is 1.3 hours per bus.

Labor time required to perform recall R09PE on buses **with** a pass-through luggage box is 1.5 hours per bus.

Warranty applications may be submitted to Blue Bird iWarranty (Campaigns/Claims).

Dealers should request parts to perform Recall R09PE from Blue Bird Recall Administration for stock units or upon customer's request. Body numbers should be provided for each request for parts.

Federal law requires that any vehicle lessor receiving this recall notice must forward a copy of this notice to the lessee within ten days.

Dealers are reminded of their responsibilities under section 154 of The National Traffic and Motor Vehicle Safety Act of 1991. Dealers are required to complete modifications on units in their inventory before delivering to the final owner. Reference Blue Bird Body Company Distributor Memo No. 42-92.

Questions regarding this recall campaign should be directed to me at (478) 822-2242.

Thank you,

A handwritten signature in cursive script that reads "Bill Coleman".

Bill Coleman
Corporate Recall Administrator
Blue Bird Corporation



R09PE

June 25, 2009

Dear Blue Bird Owner:

This notice is sent to you in accordance with the requirements of the National Traffic and Motor Vehicle Safety Act.

Blue Bird Corporation has decided that certain 2003 through 2010 model year Blue Bird All American rear engine school buses manufactured from July 16, 2003 through April 10, 2009 and equipped with optional plug style vandal lock fail to conform to the requirements of Federal Motor Vehicle Safety Standard No. 571.217.S5.2.3.3.

The subject buses may be started and/or operated with the emergency door or rear emergency window vandal lock engaged. A locked emergency exit may result in personal injury or death in the event of a vehicle crash. Blue Bird is conducting a recall to correct this condition. The subject buses must be modified according to the enclosed instructions for Recall R09PE.

Your Blue Bird bus(es) affected by this recall are identified by body serial number(s) on the enclosed reply sheets. If you no longer own the subject bus(es), please complete the appropriate section of the **yellow** reply sheet and return to Blue Bird in the enclosed pink postage prepaid envelope.

To receive parts required to correct this condition, you must sign and return the yellow reply sheet to Blue Bird in the pink self addressed postage prepaid envelope. Modification parts will be shipped "No Charge" to you via UPS.

A qualified technician should perform this recall. You may contact your Blue Bird dealer to arrange to have this recall performed. Or, if you prefer, you may perform this recall yourself or have a qualified repair facility convenient to you perform this recall.

Labor time required to perform recall R09PE on buses **without** a pass-through luggage box is 1.3 hours per bus.

Labor time required to perform recall R09PE on buses **with** a pass-through luggage box is 1.5 hours per bus.

Reimbursement for labor may be obtained by completing the **pink** request for reimbursement sheet provided and returning it to Blue Bird in the enclosed **pink** postage prepaid envelope.

BLUE BIRD CORPORATION
P.O. Box 937 • Fort Valley, Georgia 31030
Phone: (478) 825-2021

If the modifications directed by this notification were performed on your bus prior to the receipt of this recall notification, complete and sign the recall reply sheet and attach a copy of the work order/invoice. Mail the documents in the pink self-addressed postage paid envelope included with the recall notification to Blue Bird for warranty consideration. Reimbursements will be made in accordance with the requirements of the National Highway Transportation Safety Act, Title 49 Code of Federal Regulations, Parts 573 and 577.

Federal law requires that any vehicle lessor receiving this recall notice must forward a copy of this notice to the lessee within ten days.

If Blue Bird Body Company should fail to or is unable to remedy this condition without charge to you, you may contact:

**ADMINISTRATOR
NATIONAL HIGHWAY TRAFFIC SAFETY ADMINISTRATION
1200 NEW JERSEY AVENUE, SE
WASHINGTON, D.C. 20590**

Or, you may call The National Highway Traffic Safety Administration toll free at:

1-888-327-4236
TTY 1-800-424-9153

Or, go to: [HTTP://WWW.SAFERCAR.GOV](http://WWW.SAFERCAR.GOV)

Questions regarding this recall campaign should be directed to me at (478) 822-2242.

Thank you,



Bill Coleman
Corporate Recall Administrator
BLUE BIRD CORPORATION



Vandal Lock Starter Wiring

MODELS AFFECTED: 2003-2010 All American Rear Engine models with Vandal Lock Options

RECALL

ISSUE

Vehicle can be started from rear control box with Vandal locks engaged.

CORRECTIVE ACTION

Modify vehicle starter wiring to prevent vehicle start-up from rear control box while vandal locks are engaged.

WARNING Always follow all Federal, State, Local, and Shop safety standards and use proper safety equipment when performing this procedure.

PROCEDURE

- 1** Park the bus on a level surface, apply parking brakes, turn off engine, remove ignition key and chock wheels.
- 2** Disconnect the batteries removing the negative cable first.
- 3** At the Master Chassis Harness Relay Box located behind the Driver's side front access panel:

3.1 Remove six fasteners securing the windshield washer hose and the interior access panel.



Screw
Behind Driver's Side Front Access Panel

3.2 Pull out and press down the interior access panel exposing the Master Chassis Harness Relay Box. *Note: Panel may be completely removed by removing center screw in lower flange.*

3.3 Note the relay positions. *Note: Reference decal on back of access panel moved in previous step.* Remove relays to access two screws that secure the relay box. Remove the screws.

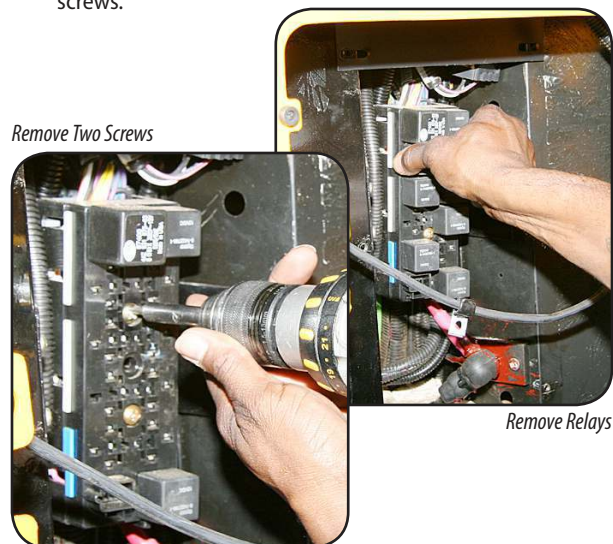

Remove Two Screws

Remove Relays

3.4 Pull the relay box forward, turn it around to access the rear cover. Remove the cover by pushing in the gray locking tabs located on both sides of the box.

3.5 Locate 16 gauge purple wire **1008**, that runs to the IGN dropout relay (4th down on left). Cut wire **1008** and tape the stub wire at the relay.

3.6 Locate 18 gauge yellow wire **1009**, that runs to the Vandal Lock Relay (5th down on right). Cut wire **1009** about 4 inches back from the relay.

R09PE

RECALL CAMPAIGN



RECALL

3.7 Strip the purple wire 1008 and yellow wire 1009 from the main harness 1/2 inch from the ends. Splice wires together using butt connector provided (BB #00036507).

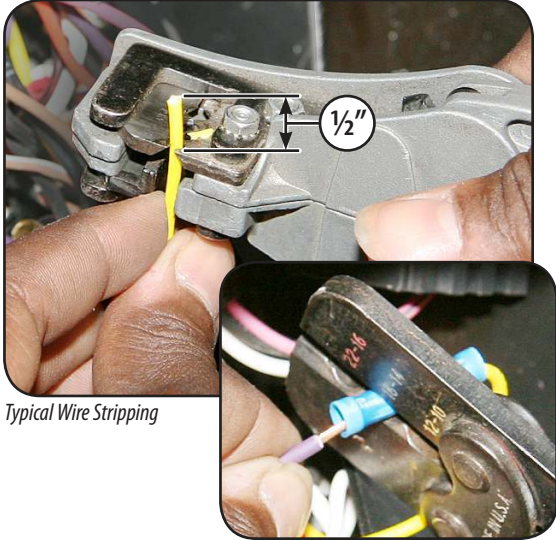

Typical Wire Stripping

Typical Wire Splicing

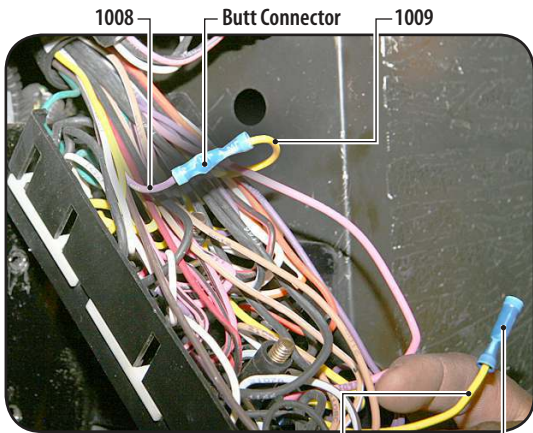

4" Yellow Wire from Vandal Lock Relay
Splice to new loomed wire provided.

3.8 Strip the 16 gauge loomed wire provided (BB #01871300) and the 4 inch yellow 18 gauge wire coming from the Vandal Lock Relay (referenced in step 3.6) 1/2 inch from the ends. Splice wires together using butt connector provided (BB #00036507).

3.9 Pry back insulation material below relay box to create an access to the chassis for routing free end of 14 gauge loomed wire to the rear of the bus.



Wiring Access to Chassis

3.10 Insert free end of loomed wire thru the access created in step 3.9 and feed through the remaining wire.

3.11 Reinstall relays removed in step 3.3.

4 From underneath the bus, using existing wire harness routing as a guide, route the wire along the inside of the chassis frame to the engine compartment. Route wire to the Rear Engine Control Box and secure to existing harness as needed with wire ties.

5 At Rear Engine Control Box in the engine compartment:

5.1 Remove Deutsch connector from the Rear Engine Control Box. Locate pin positions "X" and "W".

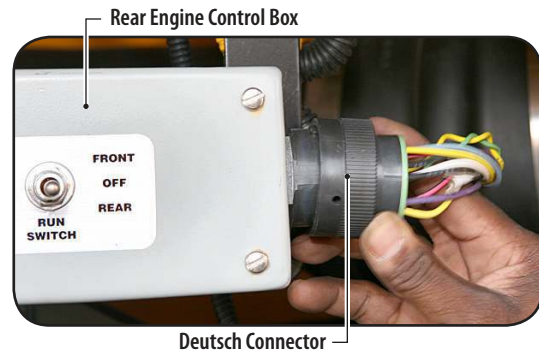

R09PE

RECALL CAMPAIGN



5.2 Remove the wire in pin position "W" using blue Deutsch extraction tool provided with parts. Cut off the terminal and strip wire 1/2 inch from the end. Splice to the new wire that was run through the chassis, using butt connector provided (BB #00036507).

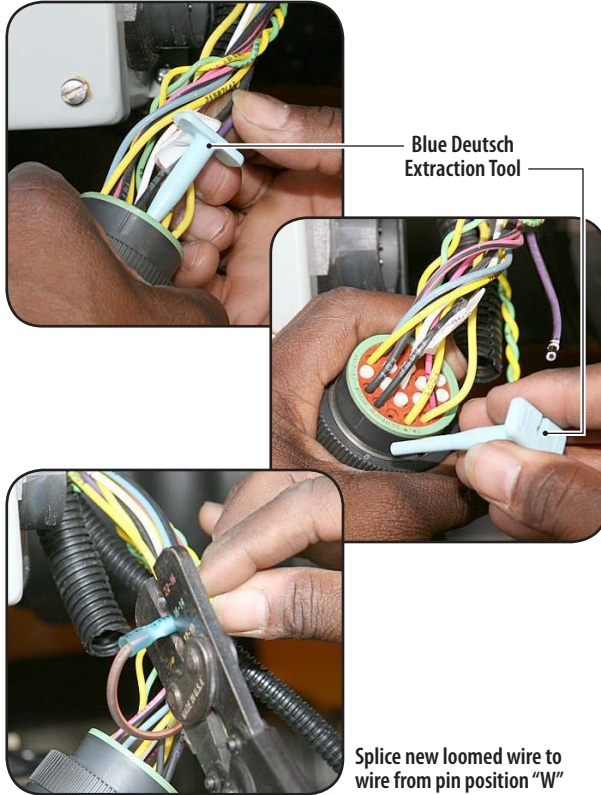

5.3 Remove the wire in pin position "X" and place in pin position "W".

5.4 Reinstall Deutsch connector.

6 Reconnect the batteries installing the negative battery cable last.

7 With new wiring in place test the circuit:

With the Vandal Lock active (keyed cylinder installed) the starter should not engage to start the engine.

7.1 Set the Run Switch on the engine compartment control panel to "Rear" and try to start the engine with the Engine Start switch. The engine should **NOT** start.

7.2 Set the Run Switch on the engine compartment control panel to "Front" and try to start the engine with the ignition key. The engine should **NOT** start.

7.3 Deactivate the Vandal Lock by removing the keyed cylinder.

7.4 With the Run Switch on the engine compartment control panel set to "Front", using the ignition key, start the engine. The starter should engage, starting the engine. Switch engine off.

7.5 From the rear engine compartment control panel set the Run Switch to "Rear" and try to start the engine with the Engine Start switch. The starter should engage, starting the engine. Switch engine off.

8 Reinstall the gray relay box cover and secure the relay box with the screws removed in step 3.3.

9 Reinstall access panel and windshield washer fluid hose removed in step 3.1.

10 Remove wheel chocks and place bus back in service.

PARTS LIST

PART NUMBER	QUANTITY	DESCRIPTION
00036507	3	Terminal, Butt Connector
01871300	60 feet	Wire, 16 Gauge
02272862	60 feet	Loom, Corrugated, Black
00599704	30	Tie, Cable
00015909	1	Tool, Term Removal, Deutsch