



R09PF

DATE: JUNE 30, 2009

TO: U.S. DEALERS

**SUBJECT: RECALL R09PF INSUFFICIENT TORQUE ON STEERING
GEAR MOUNTING FASTENERS**

This notice is sent to you in accordance with the requirements of the National Traffic and Motor Vehicle Safety Act.

Blue Bird has decided that a defect which relates to motor vehicle safety exists on certain 2009 model year All American school buses manufactured from July 22, 2008 through November 22, 2008.

On the subject buses, the steering gear mounting fasteners may not have been properly torqued. Improperly torqued fasteners may cause the steering gear to separate from the chassis frame which could result in a loss of steering control, possibly resulting in a vehicle crash. Blue Bird is conducting a recall to correct this defect. The steering gear mounting fasteners on the subject buses must be inspected and, if needed, torqued to the specifications provided in the enclosed instructions for Recall R09PF.

If our records indicate affected buses were delivered in your service area, a printout identifying affected buses is enclosed. **Dealers should verify correct owners and assure that complete shipping addresses are provided for each listed vehicle.**

If you have in your possession or have sold a bus that was purchased from another dealer that may be affected by this recall, please notify me at 478-822-2242.

Labor time to inspect and torque steering gear mounting fasteners is on e(1) hour per bus.

Warranty applications for labor reimbursement may be submitted to Blue Bird iWarranty (Campaigns/Claims).

Federal law requires that any vehicle lessor receiving this recall notice must forward a copy of this notice to the lessee within ten days.

Dealers are reminded of their responsibilities under section 154 of The National Traffic and Motor Vehicle Safety Act of 1991. Dealers are required to complete modifications on units in their inventory before delivering to the final owner. Reference Blue Bird Body Company Distributor Memo No. 42-92.

Questions regarding this recall campaign should be directed to me at (478) 822-2242.

Thank you,

A handwritten signature in cursive script that reads "Bill Coleman". The signature is written in black ink and is positioned above the typed name.

Bill Coleman
Corporate Recall Administrator
Blue Bird Corporation



R09PF

June 30, 2009

Dear Blue Bird Owner:

This notice is sent to you in accordance with the requirements of the National Traffic and Motor Vehicle Safety Act.

Blue Bird has decided that a defect which relates to motor vehicle safety exists on certain 2009 model year All American school buses manufactured from July 22, 2008 through November 22, 2008.

On the subject buses, the steering gear mounting fasteners may not have been properly torqued. Improperly torqued fasteners may cause the steering gear to separate from the chassis frame which could result in a loss of steering control, possibly resulting in a vehicle crash. Blue Bird is conducting a recall to correct this defect. The steering gear mounting fasteners on the subject buses must be inspected and, if needed, torqued to the specifications provided in the enclosed instructions for Recall R09PF.

A qualified technician should perform this recall. You may contact your Blue Bird dealer to arrange to have this recall performed. Or, if you prefer, you may perform this recall yourself or have a qualified repair facility convenient to you perform this recall.

Your Blue Bird bus(es) affected by this recall are identified by body serial number(s) on the enclosed reply sheets. If you no longer own the subject bus(es), please complete the appropriate section of the **pink** reply sheet and return to Blue Bird in the enclosed pink postage prepaid envelope.

Labor time to inspect and re-torque the steering gear mounting fasteners is one (1) hour per bus.

Reimbursement for labor may be obtained by completing the **pink** request for reimbursement sheet provided and returning it to Blue Bird in the enclosed **pink** postage prepaid envelope.

If the modifications directed by this notification were performed on your bus prior to the receipt of this recall notification, complete and sign the recall reply sheet and attached a copy of the work order/invoice. Mail the documents in the **pink** self-addressed postage paid envelope included with the recall notification to Blue Bird for warranty consideration. Reimbursements will be made in accordance with the requirements of the National Highway Transportation Safety Act, Title 49 Code of Federal Regulations, Parts 573 and 577.

Federal law requires that any vehicle lessor receiving this recall notice must forward a copy of this notice to the lessee within ten days.

If Blue Bird Body Company should fail to or is unable to remedy this condition without charge to you, you may contact:

**ADMINISTRATOR
NATIONAL HIGHWAY TRAFFIC SAFETY ADMINISTRATION
1200 NEW JERSEY AVENUE, SE
WASHINGTON, D.C. 20590**

Or, you may call The National Highway Traffic Safety Administration toll free at:

1-888-327-4236
TTY 1-800-424-9153

Or, go to: [HTTP://WWW.SAFERCAR.GOV](http://WWW.SAFERCAR.GOV)

Questions regarding this recall campaign should be directed to me at (478) 822-2242.

Thank you,



Bill Coleman
Corporate Recall Administrator
BLUE BIRD CORPORATION



Steering Gear Bolts

RECALL

MODELS AFFECTED: 2009 All American Forward Engines and Rear Engines

ISSUE

Steering gear mounting bolts may have been incorrectly torqued at installation.

CORRECTIVE ACTION

Inspect and re-torque the four bolts that attach the steering gear to the frame rail.

WARNING Always follow all Federal, State, Local, and Shop safety standards and use proper safety equipment when performing this procedure.

PROCEDURE

1 Park the bus on a level surface, apply parking brakes, switch engine off and chock wheels.

2 Disconnect the batteries removing the negative cable first.

WARNING When working underneath a vehicle, always support the unit with jack stands under the frame rail.

For easier access to the steering gear fasteners, additional clearance underneath the bus can be provided by raising the bus by means of a suitable floor jack or hydraulic lift/s. Raise the bus as needed and place suitable jack stands under each frame for support.

3 Inspect the bolts and nuts for any damage. If damaged, replace, **DO NOT** re-torque. If damage exist and new fasteners are required, contact:

Blue Bird Body Company
Attn: Recall Administrator
P.O. Box 937
Fort Valley, Georgia 31030
Phone: 478-822-2242

4 If no damage exist, re-torque the fasteners to 270-300 ft. lbs. See diagram below.

5 Remove jack stands if used and lower the bus.

6 Reconnect the batteries installing the negative battery cable last.

7 Remove wheel chocks and place bus back into service.

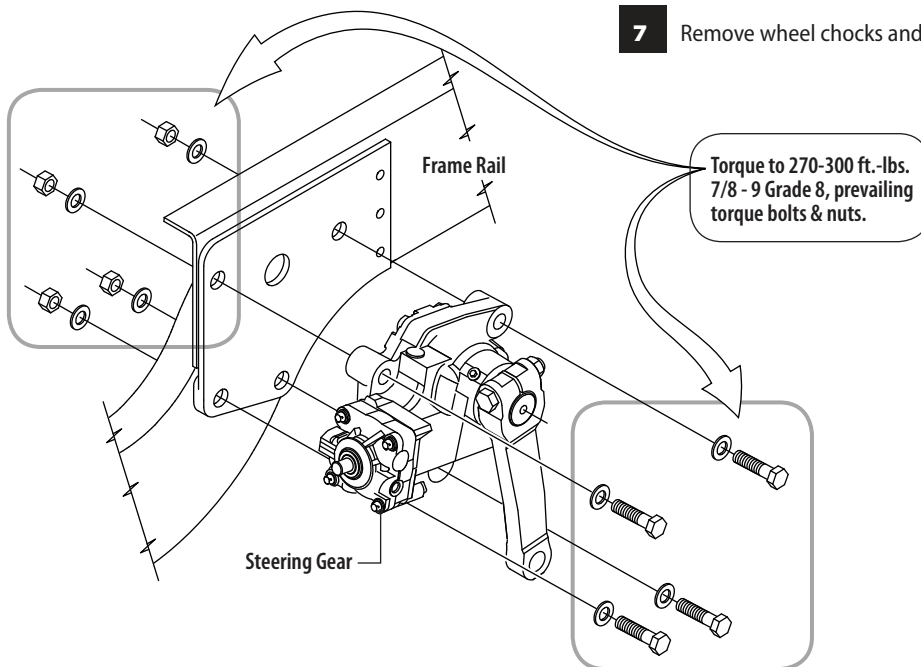

R09PF

RECALL CAMPAIGN